

DRAFT KENYA STANDARD

DKS 1515:2019

ICS 43.040.60

Second Edition

**Road vehicles — Inspection of road
vehicles — Code of practice**



**Kenya Bureau of
Standards**

Standards for Quality life

TECHNICAL COMMITTEE REPRESENTATION

The following organizations were represented on the Technical Committee:

Egerton University
Isuzu East Africa Limited.
Kenya Accreditation Service (KENAS)
Kenya Association of Bus Manufacturers (KABM)
Kenya Association of Motor Repairers (KEMRA)
Kenya Auto Bazaar Association (K.A.B.A)
Kenya Industrial Research and Development Institute (KIRDI)
Kenya Vehicle Manufacturers (KVM) Ltd
Matatu Owners Association of Kenya
Ministry of Infrastructure, Transport, Housing and Urban Development – Transport and Mechanical Directorate
Mobius (K) Limited
Motor Assessors Association of Kenya
Nairobi Metropolitan Area Transport Authority (NaMATA)
National Transport and Safety Authority (NTSA)
Olive Technical Services Ltd
Technical University of Kenya
Toyota Kenya Limited |
Kenya Bureau of Standards — Secretariat

REVISION OF KENYA STANDARDS

In order to keep abreast of progress in industry, Kenya Standards shall be regularly reviewed. Suggestions for improvements to published standards, addressed to the Managing Director, Kenya Bureau of Standards, are welcome.

© Kenya Bureau of Standards, 2019

Copyright. Users are reminded that by virtue of Section 25 of the Copyright Act, Cap. 130 of 2001 of the Laws of Kenya, copyright subsists in all Kenya Standards and except as provided under Section 25 of this Act, no Kenya Standard produced by Kenya Bureau of Standards may be reproduced, stored in a retrieval system in any form or transmitted by any means without prior permission in writing from the Managing Director.

DRAFT KENYA STANDARD

DKS 1515:2019

ICS 43.040.60

Second Edition

Road vehicles — Inspection of road vehicles — Code of practice

Kenya Bureau of Standards, Popo Road, Off Mombasa Road,
P.O. Box 54974 - 00200, Nairobi, Kenya



+254 020 6948000, + 254 722202137, + 254 734600471



info@kebs.org



@KEBS_ke



kenya bureau of standards (kebs)

DKS 1515: 2019

Foreword

This Kenya Standard was prepared by the Road vehicles Technical Committee under the guidance of the Standards Projects Committee, and it is in accordance with the procedures of the Kenya Bureau of Standards

This second edition cancels and replaces the first edition (KS 1515:2000), which has been technically revised.

During the preparation of this standard, reference was made to the following document (s):

KS ISO 6518-1, Road vehicles — Ignition systems, Part 1. Vocabulary.

KS ISO 6518-2, Road vehicles — Ignition systems, Part 2. Electrical performances and function test methods.

KS ISO 3780, Road vehicles — World Manufacturer Identifier (WMI) code.

ISO 6597, Road vehicles — Hydraulic braking systems — Measurement of braking performance.

KS ISO-3833, Road vehicles — Types, terms and definitions.

KS EAS, Specification for new pneumatic tyres — Passenger cars.

KS EAS Specification for retreaded car and commercial vehicles tyres.

KS 06-849, Specification for apparatus for measurement of the opacity of exhaust gas from diesel engines road vehicles.

KS 06-848, Specification for wheel rims — Nomenclature, designation and units of measurements.

KS 06-664 Specification for seat belt assemblies for motor vehicles.

KS ISO 3779 Road vehicles — Vehicle identification number (VIN) — Content and structure.

The MOTC — Vehicle Inspection Manual (June/July 1999 Edition).

The MOT Inspection Manual — United Kingdom.

Acknowledgement is hereby made for the assistance derived from this (these) sources.

Contents

Page

Foreword	iv
1 Scope	1
2 Normative references	1
3 Terms and definitions	1
4 General requirements	2
5 Safety requirements	3
5.2 Steering Control	3
5.1.1 Steering wheel	3
5.1.2 Steering column	3
5.2 Track rods and tie rods	3
5.3 Wheel hubs/stub axles	4
5.4 Condition of tyres	4
5.5 Electrical wiring and equipment and lighting system	4
5.5.1 Battery condition	4
5.5.2 Switchgear and wiring:	4
5.5.3 Warning lights	5
5.5.4 Headlamps	5
5.5.5 Rear lamps	5
5.5.6 Direction indicators	5
5.5.7 Hazard warning lamps	5
5.5.8 Obligatory reflectors	5
5.6 Braking systems and components	6
5.6.1 Mechanical components	6
5.7 Suspension	8
5.8 Windscreen glass	9
5.9 Seat Belts	9
5.10 General Items	10
5.10.1 Driver's Mirrors	10
5.10.2 Windscreen Wipers and Washers	10
5.10.3 Windscreens	10
5.10.4 PSV windows	10
5.11 General condition of the vehicle structure	11
5.11.1 Body Security	11
5.11.2 Body Condition	11
5.11.3 Doors	11
5.11.4 Cab doors	12
5.11.5 Load Security	12
6 Environmental requirements and exhaust emissions testing	13
6.1 New vehicles	13
6.2 In service vehicles	13
6.2.1 Visual inspection (all vehicles)	13
6.2.2 Standard emissions test	13
6.2.3 Noise level test	15
7 Inspection, tests and test equipment	15
8 Criteria of conformity	18
9 Marking	19
10 Packaging	19
11 Application for inspection and vehicle inspection test report	19

Road vehicles — Inspection of road vehicles — Code of practice

1 Scope

1.1 This code of practice specifies general, safety and environmental requirements for Road Vehicles and includes inspection schedule for Road Vehicles.

1.2 This Kenya Standard applies to all categories of Road Vehicles as specified in KS ISO 3833.

1.3 The standard also applies to inspection of motor vehicles as per the Traffic Act, Cap. 43 of the Laws of Kenya, including Hybrid Electric Vehicles (HEVs) and Electric Vehicles (EVs). A paragraph.

2 Normative references

The following referenced documents referred to in the text in such a way that some or all of their content constitutes requirements of this document. For dated references, only the edition cited applies. For undated references, the latest edition of the referenced document (including any amendments) applies.

KS ISO 3833, *Road vehicles — Types, terms and definitions*

KS 2499, *Road vehicles - Inspection centre evaluation - Code of practice*

Traffic Act, Cap. 43 of the Laws of Kenya.

3 Terms and definitions

For the purposes of this document, the following terms and definitions apply.

3.1

initial inspection

an inspection which a new motor vehicle receives when it is newly operated

3.2

periodic inspection

an inspection which a motor vehicle receives when it is to be operated continually after the term of validity of the motor vehicle inspection certificate has expired

3.3

modification inspection

an inspection, which a motor vehicle receives when there are changes in the length, height, width, maximum payload and other major specifications

DKS 1515: 2019

3.4

on-roads random inspection

an inspection, which a motor vehicle receives when it is picked up at random on the road

3.5

EV (Electric Vehicle)

a vehicle that is powered by electric power train only and a vehicle with a hydrogen fuel cell is considered an electric vehicle

3.6

HEV (Hybrid Electric Vehicle)

a vehicle powered by a power train that consists of both an internal combustion engine and an electrical energy/power storage device

3.7

vehicle category

a class or division of a vehicle regarded as having particular shared characteristics (see annex A).

4 General requirements

4.1 Authorization before importation

All road vehicles shall be subjected to inspection carried out by an authorized government body before importation.

4.2 Inspection before registration

All road vehicles shall be subjected to inspection by the Kenya Government Vehicle Inspection Centre or any other authorized and accredited vehicle inspection agent before registration.

4.3 Certificate of roadworthiness

Imported road vehicles shall be accompanied by a certificate of roadworthiness from the exporting country.

4.4 Inspection centres

Road vehicles shall be inspected in inspection centres approved by relevant authority.

4.5 Inspection centre equipment and personnel

4.5.1 Equipment used in inspection centres shall be certified by an authorized authority.

4.5.2 The vehicle inspection personnel shall be authorized inspectors with the following minimum qualifications:

- a) Diploma in motor vehicle engineering or its equivalent
- b) Qualification in inspection course awarded by a recognized training institution.
- c) Experience of not less than 5 years in the motor Industry
- d) Valid Driving Licence

4.7 Vehicle type of drive

Left hand vehicles shall be not accepted.

4.8 Age limit

4.8.1 All non-commercial road vehicles which are more than eight years old from the year of first registration shall not be allowed for importation. The difference between the year of first registration and the year of manufacture shall not be more than one year.

4.8.2 All commercial road vehicles, which are more, than:

- a) five years old from the year of first registration shall not be allowed for importation as from 1st July 2019
- b) three years old from the year of first registration shall not be allowed for importation as from 1st July 2021
- c) zero years old from the year of first registration shall not be allowed for importation as from 1st July 2024

4.9 Radio frequency range

All road vehicles, if fitted with radios, shall have the radios with a frequency range of 87.5 to 108.0 MHz.

NOTE This requirement becomes effective 6 months from date of gazettelement of this standard or as may be determined by the Communication Authority of Kenya.

5 Safety requirements

Road vehicles shall be inspected for safety requirements in accordance with the authorized inspection manual. The following defects shall be checked:

5.2 Steering Control

Defects to be examined for steering control shall be the steering wheel and the steering column.

5.1.1 Steering wheel

The steering wheel shall be examined for:

- a) Excessive 'free' play of the steering wheel. Specify how many millimetres it should move on either side from the centre
- b) Steering wheel (hub, rim, spokes) fractured
- c) Steering wheel (hub, rim, spokes) insecure
- d) Steering wheel loose to column shaft
- e) Steering wheel retaining device missing.

5.1.2 Steering column

Steering column shall be examined for:

- a) Excessive lift or side movement of steering column
- b) Steering column coupling excessively deteriorated/worn/insecure

5.2 Track rods and tie rods

DKS 1515: 2019

The track rods and tie rods shall be examined for:

- a) Excessive wear in track rod ends
- b) Excessive wear in tied rod ends
- c) Burst rubber grease retainers.

5.3 Wheel hubs/stub axles

The wheel hubs/stub axles shall be examined for:

- (a) Excessive play in wheel bearings
- (b) Excessive play in kingpins/king bushes.

5.4 Condition of tyres

The defects to be checked for condition of tyres shall be the following:

- a) Tyre walls in contact
- b) Tyre bulging
- c) Tyre has a break in fabric or cut which is more than 25 mm long or 10 per cent of tread width (whichever is greater)
- d) Tyre incorrectly inflated
- e) Tyre tread worn beyond legal limit
- f) Tyre fouling
- g) Recut tyre fitted.

5.5 Electrical wiring and equipment and lighting system

The defects to be examined for electrical wiring, equipment and lighting system shall be the battery condition, switchgear and wiring, warning lights, headlamps, rear lamps, direction indicators and hazard warning lamps and rear markings and reflectors.

NOTE When checking the condition and security of the wiring, care needs to be taken when inspecting the high voltage systems of Hybrid Electric Vehicles and Electric Vehicles. These high voltage wires are colour coded orange.

5.5.1 Battery condition

- a) Battery insecure
- b) Battery leaking
- c) Battery box not vented
- d) Battery cell closures insecure/missing
- e) Check for loose battery terminals and sulphation on the terminals
- f) Check for proper insulation of the terminals and keep away any metallic substances that may cause accidental starting.

5.5.2 Switchgear and wiring:

- a) Wiring insecure/inadequately insulated/insulation is or will become ineffective due to chafing or heat

- b) Lighting switch insecure/malfunctioning
- c) Switch not marked.

5.5.3 Warning lights

Warning lights not marked.

5.5.4 Headlamps

- a) Obligatory headlamps inoperative/missing/obscured/dim/flickers when tapped by hand
- b) Obligatory headlamps insecure or lens broken or missing
- c) Obligatory headlamps cannot be switched on or off together
- d) Aim of the headlamps too high or too far to the right
- e) Aim of the headlamps too low or too far to the left
- f) Not more than two spot lights should be fitted, whose wattage and intensity should be of the same level as the headlights
- g) Spotlights switch should be independent of the headlights switch.

5.5.5 Rear lamps

- a) Obligatory rear lamps insecure
- b) Obligatory rear lamps inoperative/missing/dim/obscured/affected by the operation of another lamp/lens broken or missing
- c) Obligatory rear lamp has intermittent operation, flickers when tapped or does not face the rear, lens broken or missing
- d) No rear lamps shall be fitted at a distance of more than 150 mm from the extreme ends of the body.

5.5.6 Direction indicators

- a) Direction indicator insecure. Detachment imminent
- b) Direction indicator missing/inoperative/not functioning correctly/damaged/obscured/lens broken or missing. Check if indicator cannot be used to clearly show the driver's intention.
- c) Indicator warning lamp inoperative/not fitted.

5.5.7 Hazard warning lamps

- a) Hazard warning lamp inoperative/not functioning correctly
- b) Side repeater indicator inoperative/not functioning correctly.
- c) Rear markings
- d) Insecure partially or correctly missing, incorrectly located or not clearly visible from the rear/detachment
- e) Incorrect rear markings fitted.

5.5.8 Obligatory reflectors

- a) Obligatory reflectors missing/deteriorated/incorrectly fitted/obscured/insecure/detachment imminent

DKS 1515: 2019

- b) HGV side reflector missing, deteriorated or of incorrect colour
- c) HGV side reflector not correctly fitted or not plainly visible from the side.

5.6 Braking systems and components

The defects to be checked for the braking systems and components shall be on the mechanical components, ABS components, air compressor drive, air/vacuum reservoir, brake valves, brake pipes and hoses, servos, brake actuators, hydraulic systems, hydraulic brake cylinder, actuator/brake cylinder travel and brake travel indicators.

5.6.1 Mechanical components

- a) Any brake component excessively worn/corroded/fractured/reduced in diameter/number of strands reduced
 - i) Any retaining/locking device missing/insecure
 - ii) Brake backplate/disc loose
 - iii) Abnormal movement of levers indicating maladjustment
 - iv) Automatic brake slack adjuster component missing/disconnected/insecure or inoperative
 - v) Brake disc fractured/excessively worn/insert insecure
 - vi) Brake drum fractured/excessively worn
 - vii) Brakelining/pad missing/excessively worn/insecure
 - viii) Severely contaminated pad/lining.

- b) ABS components

Any component forming part of an anti-lock braking system missing/damaged/disconnected.

- c) Air compressor drive

Drive belt(s) missing/badly deteriorated/loose.

- d) Air/vacuum reservoir

Brake air/vacuum reservoir damaged/excessively corroded/insecure.

- e) Brake valves

- i) Brake valve inoperative
- ii) Brake valve insecure
- iii) Brake valve damaged/fractured/excessively corroded

- iv) Brake valve leaking
 - v) Load sensing valve missing/seized/by passed, linkage defective/disconnected or out of adjustment
 - vi) Excessive oil/contaminant discharge from brake valves.
- f) Brake pipes and hoses
- i) Brake pipe excessively chafed/damaged
 - ii) Brake pipe corroded
 - iii) Brake pipe inadequately clipped/supported/repared
 - iv) Brazed or welded steel brake pipes should be inspected
 - v) Brake pipe fouling
 - vi) Brake hose chafed/deteriorated/stretched/bulging/kinked/twisted/fouling/exposed to excessive heat
 - vii) Brake pipe/hose/coupling/connection leaking.
- g) Servos
- i) Brake servo insecure
 - ii) Brake servo damaged/incorrectly fitted/fractured/excessively corroded
 - iii) Excessive travel of brake servo
 - iv) Servo losing vacuum
- h) Brake actuators
- i) Air/vacuum actuator insecure/damaged/fractured/excessively corroded/incorrectly fitted
 - ii) Loss of air/vacuum.
- i) Hydraulic systems
- i) Brake master cylinder/reservoir/wheel cylinder/calliper insecure
 - ii) Brake master cylinder/wheel cylinder/calliper damaged/incorrectly fitted/fractured
 - iii) Brake fluid leaking from ... (specify source)
 - iv) Absence of or low fluid level in hydraulic brake fluid reservoir.
- j) Hydraulic brake cylinder
- i) A hydraulic cylinder mounting insecure/cracked/fractured/damaged or a stop pin or locking device missing or insecure

DKS 1515: 2019

ii) A hydraulic cylinder leaking.

k) Actuator/brake cylinder travel

Excess or restricted travel of brake actuator or cylinder.

l) Brake travel indicators

i) Brake piston/diaphragm travel indicator missing/inoperative

ii) Brake adjustment indicator shows that brake adjustment is necessary

iii) Actuator or brake cylinder travel to be specified before it is classified as excessive.

m) Parking brake

i) Mechanical: Excess travel; Ratchet not holding lever; cables stretched or frayed; operating levers at drum damaged or seized; brake not holding vehicle stationary on slope of 2 per cent gradient.

ii) Air operated: Lever inoperative or not locking; air leaking; brake not holding vehicle on slope of 2 per cent gradient.

5.7 Suspension

Defects to be checked for suspension shall be the suspension location, suspension units and location, leaf suspension, coil suspension, torsion bar suspension, bonded suspension, air or fluid suspension, anti-roll bars and shock absorbers.

(a) *Suspension location*

(i) A suspension retaining rubber missing/deteriorated

(ii) A suspension anchor/shackle pin insecure in its bracket

(iii) A suspension anchor/shackle pin locking device missing/ineffective/insecurely fitted

(iv) A suspension slipper bracket excessively worn/fractured/not securely fixed or rebound pin missing

(v) Radius arm or linkage bracket insecure or otherwise defective

(vi) Radius arm or linkage bracket fractured/displaced/distorted.

(b) *Suspension units and location*

(i) A suspension unit weak/insecure or otherwise defective

(ii) A suspension unit incorrectly fitted

(iii) A suspension component displaced/insecure or otherwise defective.

(c) *Leaf suspension*

- (i) Spring leaf weak – Spring ‘U’ bolts loose, broken or missing
- Coil spring fractured or weak

- (ii) Spring leaf fractured/defective
- (iii) Spring clips loose/missing/broken
- (iv) Spring centre bolt broken/missing.

(d) *Coil suspension*

Coil spring fractured.

(e) *Torsion bar suspension*

- (i) Torsion bar fractured/distorted
- (ii) Torsion bar arms secured to chassis fractured/distorted.

(f) *Bonded suspension*

Bonded suspension unit failed/deteriorate — Torsion bar brushes worn.

(g) *Air or fluid suspension*

- (i) Suspension unit leaking or deflated
- (ii) Air/fluid suspension or fluid accumulator fouling or otherwise defective
- (iii) Levelling valve inoperative/excessively worn/damaged/missing
- (iv) Check strap defective.

(h) *Anti-roll bars*

An anti-roll bar, pivot, linkage or mounting missing/insecure/fractured/malfunctioning.

(j) *Shock absorbers*

- (i) Shock absorber, pivot, linkage or mounting missing/insecure/fractured/malfunctioning
- (ii) Shock absorber leaking.

5.8 Windscreen glass

The defects to be checked for windscreen glass shall be the following:

- (a) There shall be no crack longer than 2 cm or ‘Star’ damage greater in diameter than 1.5 cm in the area of the windscreen immediately in the Driver’s line of vision.
- (b) There shall be no crack in the Windscreen longer than 15 cm in any position.
- (c) There shall be no ‘fogging’ of the Windscreen between the laminates in the area of the driver’s line of vision.
- (d) Windscreen wipers missing/inoperative/blades worn or travel inadequate.
- (e) Windscreen jets are incorrectly adjusted.

5.9 Seat Belts

DKS 1515: 2019

The defects to be checked for seat belts shall be the following:

- a) Any dangerous defect/damage/feature of a seat belt restraint system.
- b) Any obligatory seat belt missing.
- c) Any obligatory or non-obligatory seat belt inoperative/defective/insecure/ anchorage or seat mounting weak.
- d) Position of seat belt anchors in relation to the seat for driver/pass comfort.

5.10 General Items

5.10.1 Driver's Mirrors

The defects to be checked for driver's mirrors shall be the following:

- (a) If the external rear view mirror and/or glass is missing/insecure/damaged
- (b) If the interior mirror/periscope or other viewing device is missing/defective/insecure.

5.10.2 Windscreen Wipers and Washers

The defects to be checked for windscreen wipers and washers shall be the following:

- (a) If the windscreen wipers are missing/inoperative/blades worn
- (b) If the windscreen washers are not fitted/inoperative/system incomplete.

5.10.3 Windscreens

The defects to be checked for windscreens shall be the following:

- (a) The windscreen is cracked/scratched/discoloured
- (b) Windscreen not of safety glass
- (c) Driver's side window not safety glass
- (d) PSV Drivers interior door/screen not of safety glass or of a safety glazing material
- (e) PSV window not of safety glass or of a safety glazing material
- (f) PSV window glazing missing/insecure/cracked
- (g) Relevant vehicle with glass not marked with an acceptable mark.

5.10.4 PSV windows

The defects to be checked for PSV windows shall be as follows:

- (a) Louvres cracked/broken/insecure

- (b) PSV weather strip damaged/deteriorated
- (c) PSV window dirty
- (d) Window glasses to be made of clear glass
- (e) PSV window, lock and sliding handle missing/broken.

5.11 General condition of the vehicle structure

5.11.1 Body Security

Defects to be checked for body security shall be the following:

Body components and fixings (e.g. twisted locks) loose/fractured/missing.

5.11.2 Body Condition

Defects to be checked for condition of the body shall be body panelling and guard rail, PSV flap type doors and PSV luggage compartments.

(a) Body panelling and guard rail

- (i) Exterior body panel damaged/missing/protruding/insecure
- (ii) Any embellishment protruding/damaged/insecure
- (iii) Guard rail insecure/damaged and on PSVs missing where required.

(b) PSV flap type door

- (i) Flap/Door catch defective/catch missing/insecure
- (ii) Flap/Door protruding when closed/exposing sharp (jagged) edges
- (iii) Flap/Door check device missing/ineffective.

(c) PSV luggage compartments

- (i) Water leakage into luggage compartment
- (ii) Luggage compartment damaged/dirty
- (iii) Luggage compartment floor damaged/deteriorated/weak
- (iv) Luggage compartment door protruding when closed/exposing sharp (jagged) edges
- (v) Luggage compartment door holding device missing/ineffective
- (vi) Luggage compartment door check device missing/ineffective.

5.11.3 Doors

Defects to be checked for doors shall be as follows:

- (i) Door missing

- (ii) Door jammed/cannot be opened
- (iii) Door cannot be retained in the closed position
- (iv) Door hinges/catches/pillar worn/loose/insecure/weakened
- (v) Sliding door jammed/likely to become displaced/is not retained in the open or closed position
- (vi) Door holding device missing/ineffective
- (vii) Door check device missing/ineffective
- (viii) Door stiff or fails to operate
- (ix) Door operation affects braking system
- (x) Power-operated door cannot be opened manually
- (xi) Door sensitive edge not working
- (xii) 'Door open' warning device inoperative
- (xiii) Draught exclude insecure
- (xiv) Passenger doors operation severe
- (xv) Obligatory markings or fittings missing/damaged/ineffective
- (xvi) Any normally fitted exit door handle guard missing
- (xvii) Defective or missing lock
- (xviii) Worn door hinge pins
- (xix) Missing or broken slide glass
- (xx) Corroded or cracked door mounting frame
- (xxi) Worn sliding door bearing/slide rail
- (xxii) Worn, chafed or missing door weather rubber
- (xxiii) Torn or missing door inner covers.

5.11.4 Cab doors

The defects to be checked for cab doors shall be as follows:

- (i) Driver's external door of a PSV jammed/obstructed/will not fasten/difficult to open
- (ii) Door hinges, catches or pillars in such a condition that the door is difficult to close or could fly open inadvertently
- (iii) Sliding door which cannot be secured in the open or closed position and/or runners or tracks so badly worn or defective that the door cannot be opened and closed without excessive effort.

5.11.5 Load Security

The following shall be checked for load security:

- (i) Body components and fixings (e.g. twisted locks) loose/fractured/missing
- (ii) Excessive displacement of the body relative to the chassis.

6 Environmental requirements and exhaust emissions testing

6.1 New vehicles

6.1.1 All new diesel powered vehicles shall be type-approved to meet the requirements of Euro II/2 as from 1st January 2021 and Euro IV/4 as from 1st January 2024. The specific details shall be as given in Annex E.

6.1.2 All new petrol (gasoline) powered vehicles shall be type-approved to a minimum of Euro IV/4.

6.2 In service vehicles

The following environmental requirements tests shall be carried out as specified in Annex B.

6.2.1 Visual inspection (all vehicles)

The exhaust shall not emit dense blue or clearly visible black smoke. In exceptional cases, especially on certain vehicles manufactured before 1960, emissions of smoke are unavoidable due to the engine design and, consequently, these vehicles will not fail the test.

6.2.2 Standard emissions test

All gasoline/petrol powered vehicles shall meet the requirements as given in Table 2 and Table 3.

Table 2 -- Exhaust emissions for petrol powered cars

Limit	Maximum measured values at natural engine idle speed			Maximum measured values at raised engine speed and with the gearbox in neutral				
	<i>Date of first use¹</i>	<i>Carbon monoxide (CO)</i>	<i>Hydrocarbon (HC)³</i>	<i>Engine idle speed (rpm)</i>	<i>Carbon monoxide (CO)</i>	<i>Hydrocarbon (HC)</i>	<i>Lambda²</i>	<i>Engine speed (rpm)</i>
Before 1/8/75	No requirement	No requirement	No requirement	No requirement	No requirement	No requirement	No requirement	No requirement
From 1/8/75 and before 1/8/86	4.5% vol.	0.12% vol. (1 200 ppm ⁴)	No specific requirement but the engine should be at its normal idling speed	No requirement	No requirement	No requirement	No requirement	No requirement

DKS 1515: 2019

From 1/8/86 and before 1/8/95	3.5% vol.	0.12% vol. (1 200 ppm)	No specific requirement but the engine should not be clearly above its normal idling speed	No requirement	No requirement	No requirement	No requirement
From 1/8/95 and before 1/8/2002	0.5% vol.	No requirement	No specific requirement but the engine should be at its normal idling speed	0.3% vol.	0.02% vol. 200 ppm	1 ± 0.03	>2 500 rpm <3 000 rpm
From 1/8/2002	0.3% vol.	No requirement	No specific requirement but the engine should be at its normal idling speed	0.2% vol.	0.02% vol. 200 ppm	1 ± 0.03	>2 500 rpm <3 000 rpm

NOTE 1 Date of first use is as defined in Regulation 3(3) of the Road vehicles (Construction and Use) Regulations.

NOTE 2 Lambda is the ratio of the mass of air/mass of fuel divided by 14.7

NOTE 3 HC is normally measured during the natural idle test. However, where a vehicle meets the CO limit but exceeds the HC limit at this speed, the tester must carry out a further test at 2000rpm. Provided the HC limit is met at this higher speed then the vehicle meets the requirement.

NOTE 4 PPM refers to "parts per million"

Table 3 -- Exhaust emissions for other petrol powered vehicles

Limit	Maximum measured values at natural engine idle speed			Maximum measured values at raised engine speed and with the gearbox in neutral				
	Date of first use ¹	Carbon monoxide (CO)	Hydrocarbon (HC) ³	Engine idle speed (rpm)	Carbon monoxide (CO)	Hydrocarbon (HC)	Lambda ²	Engine speed (rpm)
Before 1/8/75	No requirement	No requirement	No requirement	No requirement	No requirement	No requirement	No requirement	No requirement
From 1/8/75 and before 1/8/86	4.5% vol.	0.12% vol. (1 200 ppm ⁴)	No specific requirement but the engine should be at its normal idling speed	No requirement	No requirement	No requirement	No requirement	No requirement
From 1/8/86 and before 1/8/94	3.5% vol.	0.12% vol. (1 200 ppm)	No specific requirement but the engine must not be clearly above its normal idling speed	No requirement	No requirement	No requirement	No requirement	No requirement

From 1/8/2002	0.3 % vol.	0.12% vol. (1 200 ppm)	No specific requirement but the engine should be at its normal idling speed	0.2% vol.	0.02% vol. 200 ppm	1 ± 0.03	>2 500 rpm <3 000 rpm
NOTE 1 Date of first use is as defined in the Traffic Act, Cap. 403 of the Laws of Kenya, (Construction and Use) Regulations.							
NOTE 2 Lambda is the ratio of the mass of air/mass of fuel divided by 14.7.							
NOTE 3 HC is normally measured during the natural idle test. However, where a vehicle meets the CO limit but exceeds the HC limit at this speed, the tester must carry out a further test at 2 500 rpm. Provided the HC limit is met at this higher speed then the vehicle meets the requirement.							
NOTE 4 ppm refers to 'parts per million'							

6.2.3 Noise level test

The permitted noise levels which a vehicle produces shall not exceed 90 dB. Where a person is employed as a driver of a PSV vehicle the noise which he is exposed to shall not exceed 90 dB and shall be in conformity with other laid down government regulations in operation. The test procedure shall be as specified in Annex C.

7 Inspection, tests and test equipment

7.1 An Inspection Centre shall meet all the requirements of KS 2499 and have a minimum of the tests and test equipment specified in Table 4.

Table 4 --- Tests and test equipment

Tests	Main test equipment, etc.
1. Confirmation of construction devices And functions	Pit or lift tape measure
2. Weight measurement	Weight meter
3. Front wheel alignment test	Side slip tester or wheel alignment tester
4. Rear-view mirror visibility test	Tape measure
5. Deceleration performance test of auxiliary brake system	Deceleration measuring device or speed measuring device, clock and proving ground
6. Brake test	<p>Stopping distance measuring device, vehicle speed detecting device and proving ground</p> <p>NOTE 1 Attention is to be aid to Hybrid Electric Vehicles (HEVs) and Electric Vehicles (EVs). Due to the nature of the control systems some vehicles cannot be tested on the Roller Brake Tester and must receive a decelerometer brake test.</p> <p>NOTE 2 Some vehicles have a regenerative braking system connected to the service brake system. If the regenerative system cannot be disconnected from the service brake, a decelerometer brake test is required. If the regenerative system can be disconnected and the vehicle control system allows a roller brake test this must be carried out.</p>
7. Brake fluid leakage warning device	Sound level meter, microphone, pedal application force meter and fluid quantity measuring instrument
8. Steady running noise level test	Sound level meter, microphone, recorder, vehicle speed detecting device and proving ground
9. Acceleration running noise level test	Sound level meter, microphone, recorder, engine tachometer and proving ground
10. Stationary noise level test	Sound level meter, microphone, recorder, engine tachometer and proving ground
11. Headlamp test	Illuminator, screen and dark room
12. Front fog lamp test	Illuminator, screen and dark room
13. Cornering lamp test	Illuminometer, screen, angle measuring instrument and dark room
14. Number plate lamp test	

	Illuminometer or luminances brightness meter, test sample plant and dark room
15. Back-up lamp test	Illuminometer, screen and dark room
16. Horn sound level test	Sound level meter and microphone
17. Idling, 10.15-mode and 11 mode exhaust emission tests	Chassis dynamometer, blower, driving schedule indication device, CVS, exhaust emission analyzer, recorder, vehicle speed meter, engine tachometer, reference gases, barometer, thermometer, hygrometer, anemometer, wind direction meter, coast-down time measuring device and test room
18. Diesel smoke concentration test (3-mode, no load quick acceleration)	Chassis dynamometer or engine dynamometer, blower, exhaust smoke sampling device, concentration measuring device, barometer and thermometer
19. Diesel 10.15-mode exhaust emission test	Chassis dynamometer, blower, driving schedule indication device, CVS, exhaust emission analyzer, integrator, recorder, vehicle speed meter, engine tachometer, reference gases, barometer, thermometer, hygrometer, anemometer, wind direction meter, coast-down time measuring device, dilution tunnel, exhaust gas introduction pipe, filter holder, sampling suction pump, diluted exhaust emission sampling flow meter, weighing balance, weighing room and test room
20. Diesel 6-mode exhaust emission test	Chassis dynamometer or engine dynamometer, blower, exhaust emission analyzer, recorder, intake air quantity measuring device, fuel consumption measuring device, engine tachometer, reference gases, barometer, thermometer, hygrometer and test room
21. Diesel 13-mode exhaust emission test	Engine dynamometer, exhaust emission analyzer, recorder, intake air quantity measuring device, fuel consumption measuring device, engine tachometer, reference gases, barometer, thermometer, hygrometer, exhaust gas introduction pipe, dilution tunnel, filter holder, sampling suction pump, diluted exhaust emission sampling flow meter, weighing balance, weighing room and test room
22. Heat-damage test	Chassis dynamometer, blower, temperature measuring device, recorder and test room
23. 10.15-mode fuel economy test	Chassis dynamometer, blower, driving schedule indication device, CVS, exhaust emission analyzer, recorder, vehicle speed meter, engine tachometer, reference gases, barometer, thermometer, hygrometer, anemometer, wind direction meter, coast-down time measuring device or wheel torque measuring device and test room

24. Confirmation of construction, devices and functions of motor vehicle which has undergone durability driving (Part 1)	Pit or lift and tape measure
25. Idling, 10.15-mode and 11-mode exhaust emission tests of motor vehicle which has undergone durability driving (Part 2)	Chassis dynamometer, blower, driving schedule indication device, CVS, exhaust emission analyzer, recorder, vehicle speed meter, engine tachometer, reference gases, barometer, thermometer, hygrometer, anemometer, wind direction meter, coast-down time measuring device or wheel torque measuring device and test room
26. Other tests/observations deemed as necessary	Devices necessary for the test concerned

7.2 The inspection schedule shall be in accordance with Table 5.

Table 5 -- Inspection schedule

Category	Initial inspection	Periodic inspection (frequency)	Modification inspection	Inspection at transfer of ownership <i>NB: This is Optional</i>	Inspection of vehicles involved In accidents	On-roads Random Inspection
Heavy duty trucks	All	12 Months	Yes	Yes	Yes	Safety Emission
Buses	All	12 Months	Yes	Yes	Yes	Safety Emission
Light-duty vehicles including passenger cars	All	12 Months	Yes	Yes	Yes	Safety Emission
Taxis	All	12 Months	Yes	Yes	Yes	Safety Emission
Motorized tricycles	All	12 Months	Yes	Yes	Yes	Safety Emission

8 Criteria of conformity

8.1 For a vehicle to be registered for use it shall be required to have the following:

- 8.1.1 A certificate of roadworthiness from a recognized agency of the exporting country.
- 8.1.2 A vehicle inspection report from an authorized vehicle inspection centre.

8.2 Prohibition of vehicle

The classification for defects shall be as per authorized manuals and shall be as follows:

- 8.2.1 *IM* — Immediate prohibition
- 8.2.2 *D* — Delayed prohibition (10 days)
- 8.2.3 *AD* — Advisory defects

8.3 All vehicles which fail the inspection test shall be deemed to require repair at the cost of the owner and will be denied renewal of road licence or insurance.

8.4 A certificate of roadworthiness shall be issued only after a vehicle has undergone inspection and has been found to have no severe defects.

9 Marking

Each road vehicle shall conform to KS ISO 3780, Road vehicles — World manufacturer identifier (WMI) code and KS ISO 3779, Road Vehicles — Vehicle identification number (VIN).

10 Packaging

Each imported vehicle shall be protected from corrosion by applying a suitable anti-corrosive agent to last for a minimum three-month period while in transit at sea.

11 Application for inspection and vehicle inspection test report

11.1 The application for inspection shall be made using Form 1 shown below:

FORM 1. APPLICATION FOR INSPECTION

<i>Form 1</i>	
APPLICATION FOR INSPECTION	
The Managing Director, Kenya Bureau of Standards, P.O. Box 54974-00200, NAIROBI.	
Date:	
Name of Applicant:	Signature:
Occupation:.....	
Organization:.....	
Address:.....	
Make and Type of Motor Vehicle	
Category of Vehicle	
VIN	
Engine No.	
Chassis No.	
Test Site Desired	
Test Date Desired	
Test Item Desired for Modification	
Name & Address of the Vehicle Inspection Centre	
Remarks	

11.2The inspection report shall be made on Form 2 shown below:

FORM 2. VEHICLE INSPECTION REPORT

VEHICLE INSPECTION REPORT

Name of Applicant:.....

Address:.....

Name and Address of Vehicle Inspection Centre:.....

Place of Inspection:..... Date of Inspection:.....

VEHICLE IDENTIFICATION

1. Make:..... Category:.....
 Type:.....
2. Reg. No:.....
3. Date of First Reg:..... Odometer Reading:..... km:.....
4. Year of Manufacture:.....
5. VIN:.....
6. Chassis No:..... Engine No:.....
7. Colour:.....
8. Sitting Capacity:.....
9. Type of Engine: Diesel ol
10. Report: If new vehicle sed

INSPECTION RESULTS

General Condition of Road Vehicle:

- IM**— Immediate Prohibition **D**— Delayed Prohibition
AD— Advisory Defects

Advisory Remarks:.....

Name of Inspector:..... Signature:..... Date:.....

Annex A
(normative)
Vehicle Categorization

Category	Description
L	Motor vehicles with less than four wheels [but does include light four-wheelers]
L1	A two-wheeled vehicle with an engine cylinder capacity in the case of a thermic engine not exceeding 50 cm ³ and whatever the means of propulsion a maximum design speed not exceeding 50 km/h.
L2	A three-wheeled vehicle of any wheel arrangement with an engine cylinder capacity in the case of a thermic engine not exceeding 50 cm ³ or 4kw and whatever the means of propulsion a maximum design speed not exceeding 50 km/h.
L3	A two-wheeled vehicle with an engine cylinder capacity in the case of a thermic engine exceeding 50 cm ³ or 4kw and whatever the means of propulsion a maximum design speed exceeding 50 km/h.
L4	A vehicle with three wheels asymmetrically arranged in relation to the longitudinal median plane with an engine cylinder capacity in the case of a thermic engine exceeding 50 cm ³ or whatever the means of propulsion a maximum design speed exceeding 50 km/h (motor cycles with sidecars).
L5	A vehicle with three wheels symmetrically arranged in relation to the longitudinal median plane with an engine cylinder capacity in the case of a thermic engine exceeding 50 cm ³ or whatever the means of propulsion a maximum design speed exceeding 50 km/h.
L6	A vehicle with four wheels whose unladen mass is not more than 350 kg, not including the mass of the batteries in case of electric vehicles, whose maximum design speed is not more than 45 km/h, and whose engine cylinder capacity does not exceed 50 cm ³ for spark (positive) ignition engines, or whose maximum net power output does not exceed 4 kW in the case of other internal combustion engines, or whose maximum continuous rated power does not exceed 4 kW in the case of electric engines.
L7	A vehicle with four wheels, other than that classified for the category L6, whose unladen mass is not more than 400 kg (550 kg for vehicles intended for carrying goods), not including the mass of batteries in the case of electric vehicles and whose maximum continuous rated power does not exceed 15 kW.
M	Vehicles having at least four wheels and used for the carriage of passengers (e.g., standard car with 2, 3, 4 doors).
M1	Vehicles used for carriage of passengers, comprising not more than eight seats in addition to the driver's = 9.
M2	Vehicles used for the carriage of passengers, comprising more than eight seats in addition to the driver's seat, and having a maximum mass not exceeding 5 tonnes. (Bus)
M3	Vehicles used for the carriage of passengers, comprising more than eight seats in addition to the driver's seat, and having a maximum mass exceeding 5 tonnes. (Bus)
N	Power-driven vehicles having at least four wheels and used for the carriage of goods
N1	Vehicles used for the carriage of goods and having a maximum mass not exceeding 3.5 tonnes. (Pick-up Truck, Van)
N2	Vehicles used for the carriage of goods and having a maximum mass exceeding 3.5 tonnes but not exceeding 12 tonnes. (Commercial Truck)
N3	Vehicles used for the carriage of goods and having a maximum mass exceeding 12 tonnes. (Commercial Truck)
O	Trailers (including semi-trailers)
O1	Trailers with a maximum mass not exceeding 0.75 tonnes.
O2	Trailers with a maximum mass exceeding 0.75 tonnes, but not exceeding 3.5 tonnes.
O3	Trailers with a maximum mass exceeding 3.5 tonnes, but not exceeding 10 tonnes.
O4	Trailers with a maximum mass exceeding 10 tonnes.
	Special purpose vehicle
	Motor caravan, also Campervan, Motorhome.
	Armored car (VIP), Armored car (valuables)

	Ambulance
	Hearse
T	Agricultural and Forestry tractors
	Non-road mobile machinery
G	Off-road vehicles

PUBLIC REVIEW DRAFT

Annex B
(normative)
Environmental requirements (Exhaust emissions testing)

The following tests shall be carried out for conformity with environmental requirements.

B1. Test procedure for petrol powered vehicles

B1.1 Visual Inspection (all vehicles) — Once the preliminary checks have been completed, the tester will raise the engine speed to around 2 500 rpm, or half the maximum engine speed if this is lower. The engine speed will be held steady for about 20 seconds then the engine will be allowed to return to its natural idle speed. Once the emissions have stabilized the tester will assess the smoke emitted from the tailpipe. If the exhaust is emitting dense blue or clearly visible black smoke then the vehicle will fail the test. In exceptional cases, especially on certain vehicles manufactured before 1960, emissions of smoke are unavoidable due to the engine design and, consequently, these vehicles will not fail the test.

B1.2 Standard Emissions Test — For vehicles first used on or after 1st August 1975, emissions will also be checked using an approved analyzer. After completing the visual test, the tester will use the analyzer to assess the concentration of carbon monoxide (CO) and hydrocarbons (HC) in the exhaust gases by inserting a sample probe into the exhaust tailpipe. The test is carried out with the engine at its normal idling speed and the analyzer displays the results continuously. Once a stabilized figure is achieved the tester will record the result.

The vehicle must comply with the emissions limits set out in Tables 3 and 4.

B2. Test procedure for diesel powered vehicles

B2.1 Vehicles to be Tested — This inspection shall apply to all diesel powered vehicles with four or more wheels.

B2.2 Checks on the Vehicle Before the Test — As a general precaution motorists and vehicle operators are advised to check that the vehicle has enough engine oil, the coolant level is correctly topped-up, and there is enough fuel to carry out the test. If defects are known or suspected before the test is carried out then it is advisable to seek advice from a qualified service engineer and have the defects rectified well in advance of the test appointment.

Wherever possible vehicles should arrive at the test station with the engine at its normal operating temperature (i.e. after a drive of around 8 kilometres).

Before carrying out the test for cars and light goods vehicles the tester must confirm that the engine is at its normal operating temperature. In most cases, this will require the use of a temperature probe inserted into the dipstick tube. The tester will also check that the engine has adequate oil and fuel to complete the test before proceeding. In addition, the tester will check the condition of the camshaft drive belt (where visible) and the fuel injection pump (governor) anti-tampering seals.

For vehicles with manual transmission the test should be carried out with the gear lever in the 'neutral' position and with the clutch engaged. For vehicles with automatic transmission the gear selector should be in either the 'neutral' or 'parking' position.

B2.3 Test Procedure

B2.3.1 All private cars and light goods vehicles (< 3 500 kg)

B2.3.1.1 Visual inspection — For vehicles first used before 1st August 1979, a visual test shall be carried out. The tester will check the smoke emissions by raising the engine speed to around 2 500 rpm or half the maximum engine speed if this is lower. Once this speed has been reached and the engine stabilized for 20 seconds, the tester will then allow the engine to return to idle. After letting the engine stabilize at this speed, the tester will assess the emissions from the exhaust tailpipe. If the exhaust is emitting dense blue or clearly visible black smoke for a period of 5 seconds or more then the vehicle will failed the test. However, vehicles manufactured before 1960, will not be failed if the smoke is unavoidable due to the engine design.

B2.3.1.2 Metered smoke test — For vehicles first used on or after 1st August 1979, a metered smoke test shall be carried out. Before checking the smoke emission the tester will first ensure that the engine speed governor is functioning by increasing the engine speed to around 2 500 rpm or half the maximum engine speed if this lower. Upon reaching this speed, the tester will hold the engine speed steady for 20 seconds then the engine speed will be slowly increased to check the operation of the fuel pump governor. Where the engine speed stabilizes at its maximum speed, indicating that the governor is not working, the engine should be returned to idle speed. Where it is clear that the governor is not working, the engine should be returned to idle speed and stopped, the smoke test will not be carried out and the tester will be unable to pass the vehicle.

Provided that the preliminary checks are completed satisfactorily, the tester will next prepare the smoke meter and insert the sampling probe to the exhaust pipe.

Having re-started the engine the tester will start the smoke test. The smoke meter will indicate to the tester when to accelerate the engine and after 2 seconds have elapsed it will display a message telling the tester to release the throttle. The meter will calculate the maximum smoke emission during the acceleration and display the result. A further two accelerations will be requested by the meter.

Provided that the average of the 3 tests is on or below the appropriate limit in Table B.1, and the three results are within a certain tolerance of each other, then the vehicle will have passed the test. The tester will stop the engine and remove the smoke meter probe from the tailpipe.

Where the average smoke emission at the end of the third acceleration exceeds the limit in Table B.1 then the meter will request further tests until either the average of the three preceding accelerations is on or below the limit in Table 5 or a maximum of six accelerations have been completed. In either case the tester will stop the test and remove the probe from the exhaust tailpipe.

Table B.1-- All diesel powered vehicles

Limit	Maximum smoke value (absorption coefficient) measured under free acceleration	
	<i>Turbocharged Engines</i>	<i>Naturally Aspirated Engines</i>
<i>Vehicle Type</i>		
Passenger cars and light commercial vehicles (< 3 500 kg) and first used before 1st August 1979	Visual assessment	Visual assessment
Passenger cars and light commercial vehicles – first used on or after 1 August 1979 and before 1 July 2008	3.0 m ⁻¹	2.5 m ⁻¹
Passenger cars and light commercial vehicles – first used on or after 1 July 2008	1.5 m ⁻¹	2.5 m ⁻¹
All other vehicles	3.0 per metre	2.5 per metre
NOTE Date of first use as defined in the Traffic Act, Cap. 403 of the Laws of Kenya.		

As a final check the tester will assess visually whether the smoke emitted from the exhaust, regardless of measured smoke density, is likely to obscure the vision of other roads users. If it is likely to do so, in the tester's opinion, then the vehicle will fail the test.

Annex C
(normative)

Test procedure for noise emitted by road vehicles

C1. The vehicle shall be driven unladen and shall approach Line AA (see Figure 1) at a steady road speed which corresponds to the engine speed of three quarters of the revolutions per minute at which (according to manufacturer) the engine develops its maximum power, under such gear ratio (excluding first gear in the case of vehicles fitted with more than three forward gears) that the road speed approaches 50 km/h as closely as possible. When the front of the vehicle reaches the position in relation to the microphone, shown as AA in Figure 1, the throttle shall be fully opened as rapidly as practicable and held there until the rear of the vehicle reaches the position BB in Figure 1, when the throttle shall be closed as rapidly as possible. This test shall be repeated with the vehicle travelling in the opposite direction.

C1.1 Trailers, including the trailer portion or articulated vehicles, shall be ignored when considering the crossing of Line BB.

C1.2 If the vehicle is fitted with more than two wheel drives, it shall be used in the drive which is intended for normal road use.

C1.3 If the vehicle is specially constructed with equipment (such as concrete mixers, compressors, pumps, etc.) which is used whilst the vehicle is in normal services on the road, the equipment should also be operating during the test.

C2. In the case of agricultural tractors, self-propelled agricultural machines, and motor cultivators, the vehicle shall approach Line AA (see Figure 1) at a steady speed of three quarters of the maximum speed which can be achieved using the gearbox ratio which gives the highest road speed.

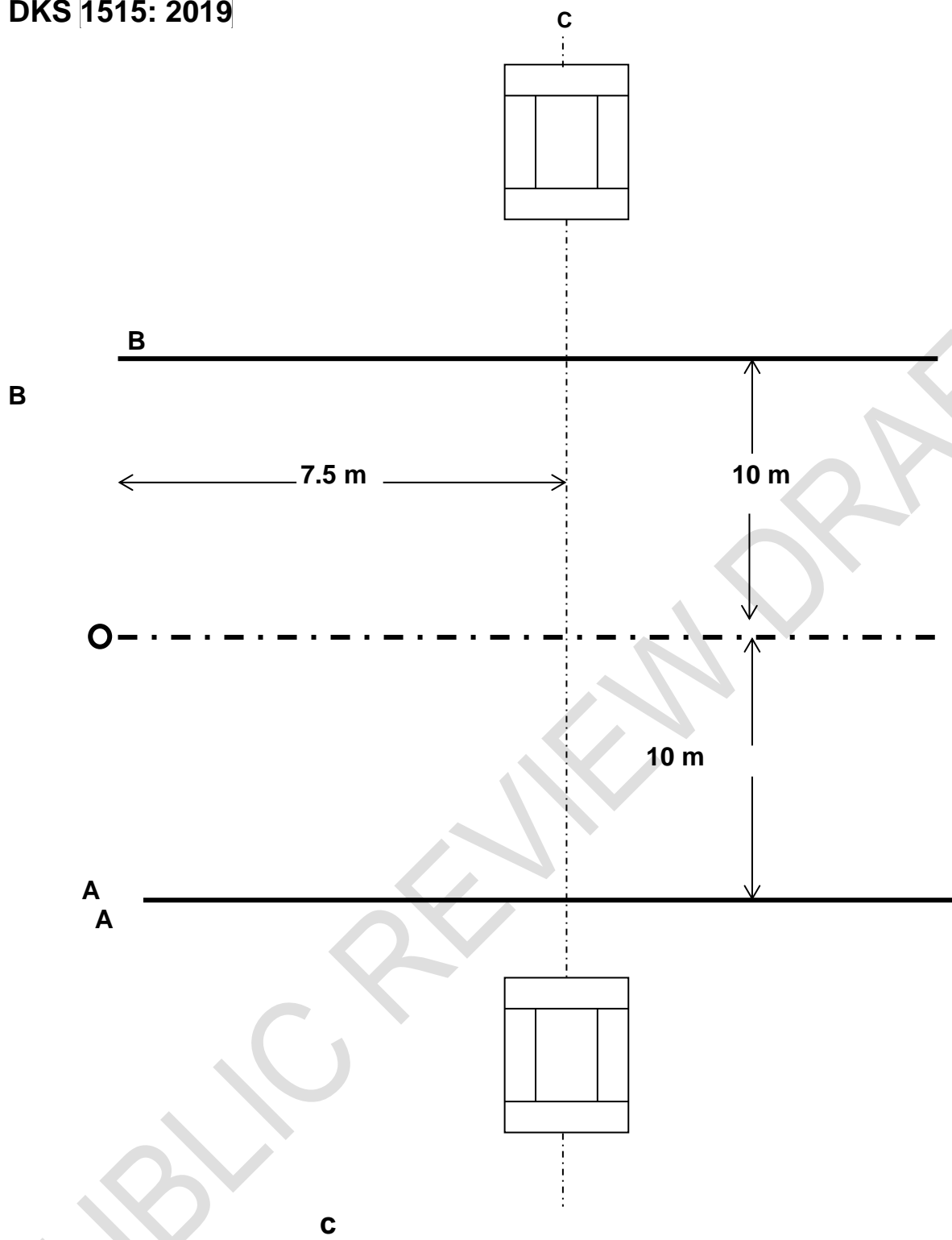

Figure 1 — Measuring positions for measurements with various vehicles in motion

Annex D
(normative)
Preliminary inspection checklist for roadworthiness

OWNER'S NAME: ADDRESS:..... TEL:.....

MAKE OF VEHICLE:..... MODEL:.....

ENGINE CAPACITY:..... MILEAGE:.....

MANUFACTURE DATE:..... REGISTRATION DATE:.....

ENGINE No:..... CHASSIS No:..... REG: No:.....

TYPE OF BODY:..... SEATING/CARRYING CAPACITY:.....

EXPIRY DATE OF CURRENT ROAD LICENCE:.....

INSURANCE No:..... EXPIRY DATE:.....

STAGE 1. BODY WORK (EXTERNAL AND INTERNAL)

ITEMS	AD ADVISORY DEFECTS	D DELAYED PROHIBITION	IM IMMEDIATE PROHIBITION
Overall appearance			
Condition of paint			
Doors			
Windows			
Sunroof			
External mirrors			
Glasses			
Wipers and washers			
Seats			
Trim			

STAGE 1. BODY WORK (EXTERNAL AND INTERNAL) (continued)

ITEMS	AD ADVISORY DEFECTS	D DELAYED PROHIBITION	IM IMMEDIATE PROHIBITION
Safety belts			
Steering wheel			
Brake pedal			
Clutch pedal			
Parking brake lever			
Headlights			
Parking lights			
Direction indicators			
Reversing light			
Courtesy light			
Rear number plate light			
Stop lights			
Front bumper			
Rear bumper			
Roof rack			
Antenna			

STAGE 2. CONDITION OF ENGINE COMPONENTS (STATIC), ENGINE COMPARTMENT AND BOOT

ITEMS	AD ADVISORY DEFECTS	D DELAYED PROHIBITION	IM IMMEDIATE PROHIBITION
Bonnet			
Engine			
Battery			
Battery carrier			
Wiring harness			
Starter motor			
Alternator/Generator			
Radiator			
Radiator hoses			
Water pump			
Caburettor			
High tension cables			
A/C Condenser			
Power steering			
Brakes master cylinder			
Clutch master cylinder			
Brake steel pipes			

STAGE 2. CONDITION OF ENGINE COMPONENTS (STATIC), ENGINE COMPARTMENT AND BOOT *(continued)*

ITEMS	AD ADVISORY DEFECTS	D DELAYED PROHIBITION	IM IMMEDIATE PROHIBITION
Fuel pipes			
Flexible brake pipes			
Windscreen washer bottle			
Boot lid			
Jack and handle			
Wheel wrench			
Tool-kit			
Life saver			

STAGE 3. ENGINE FUNCTIONING (RUNING STATE)

ITEMS	P	R	REMARKS
Radiator water			

Engine oil			
Starting of engine			
Idle speed noises			
High speed noises			
Oil leaks			
Water leaks			
Cooling system function			
Engine oil pressure			
Charging system			
A/C operation			
Power steering operation			
Fuel pump			
Vacuum pump			
Engine stopper (diesel)			
Exhaust emission			

STAGE 4. (on pit) UNDER BODY INSPECTION

ITEMS	P	R	REMARKS
Laminated leaf springs			

DKS 1515: 2019

U-bolts			
Spring bushes			
Spring pins			
Coil springs			
Front shock absorbers			
Rear shock absorbers			
Sub-frame mountings			
Engine mountings			
Gearbox mountings			
Stabilizer bar bushes			
Fuel tank			
Fuel lines			
Brake lines			
Exhaust system			
Transmission			
Steering box/rack			

STAGE 4. (on pit) UNDER BODY INSPECTION *(continued)*

ITEMS	P	R	REMARKS
Chassis			

Mono-block body			
Front sub-frame			
Rear sub-frame			
Front axle			
Rear axle			
2nd rear axle (where fitted)			
Wheel geometry			

TYRES

LOCATION	SIZE	WEAR PATTERN	TREAD DEPTH	P	R	WHEEL RIMS
FR LEFT						
FR RIGHT						
RR LEFT INNER						
RR LEFT OUTER						
RR RIGHT INNER						
RR RIGHT OUTER						
SPARE WHEEL						
REMARKS						

STAGE 5. (on pit) STEERING, SUSPENSIONS, FINAL DRIVE

ITEMS	P	R	REMARKS
King-pin bushes			

DKS 1515: 2019

Ball-joints			
Steering linkages			
Brake discs			
Calipers			
Front brake pipes			
Brake pad life			
Brake drums			
Wheel cylinders			
Rear oil seals			
Rear brake pipes			
Front L.H. driving shaft			
Front R.H. driving shaft			
Front differential			
Rear differential			
Transfer case			
Front propeller shaft			

STAGE 5. (on pit) STEERING, SUSPENSIONS, FINAL DRIVE (continued)

ITEMS	P	R	REMARKS
Centre bearing			

Front oil seals			
Rear L.H. drive shaft			
Rear R.H. drive shaft			
Hand brake cables			

STAGE 6. TEST DRIVE

ITEMS	P	R	REMARKS
Driving seat adjustments			
Driving performances			
Emergency brake			
Clutch performance			
Gear shift			
Steering stability			
Front suspension			
Rear suspension			
Gauges and instruments			

STAGE 6. TEST DRIVE (continued)

ITEMS	P	R	REMARKS
Odometer			
Heater			

DKS 1515: 2019

Defroster			
Air-con			
Windscreen wipers			
Washers			
Horn			
Wheel alignment			
Parking brake			

RECOMMENDATIONS

1. Approved for use on Kenya Roads
2. To undergo corrective repairs
3. Reject

Annex E
(informative)
Emission levels for new road vehicles

D.1 Passenger Vehicles Emission Standards

Table D.1.1 -- EU emission standards for passenger cars (Category M1)

Stage	Date	CO	HC	HC+NOx	NOx	PM	PN
		g/km					
Positive Ignition (Gasoline)							
Euro 1†	1992.07	2.72 (3.16)	-	0.97 (1.13)	-	-	-
Euro 2	1996.01	2.2	-	0.5	-	-	-
Euro 3	2000.01	2.3	0.2	-	0.15	-	-
Euro 4	2005.01	1	0.1	-	0.08	-	-
Euro 5	2009.09	1	0.10	-	0.06	0.005	-
Euro 6	2014.09	1	0.10	-	0.06	0.005	6.0×10 ¹¹

Table D.1.2 -- EU emission standards for passenger cars (Category M1)

Stage	Date	CO	HC	HC+NOx	NOx	PM	PN
		g/km					
Compression Ignition (Diesel)							
Euro 1	1992.07	2.72 (3.16)	-	0.97 (1.13)	-	0.14 (0.18)	-
Euro 2, IDI	1996.01	1	-	0.7	-	0.08	-
Euro 2, DI	1996.01	1	-	0.9	-	0.1	-
Euro 3	2000.01	0.64	-	0.56	0.5	0.05	-
Euro 4	2005.01	0.5	-	0.3	0.25	0.025	-
Euro 5a	2009.09	0.5	-	0.23	0.18	0.005	-
Euro 5b	2011.09	0.5	-	0.23	0.18	0.005	6.0×10 ¹¹
Euro 6	2014.09	0.5	-	0.17	0.08	0.005	6.0×10 ¹¹

D.2 Light Commercial Vehicles Emission Standards

Table D.2.1 -- Emission standards for light commercial vehicles

Category	Stage	Date	CO	HC	HC+NOx	NOx	PM	PN
			g/km					
Positive Ignition (Gasoline)								
N₁, Class I	Euro 1	1994.1	2.72	-	0.97	-	-	-
≤1305 kg	Euro 2	1998.01	2.2	-	0.5	-	-	-
	Euro 3	2000.01	2.3	0.2	-	0.15	-	-
	Euro 4	2005.01	1	0.1	-	0.08	-	-
	Euro 5	2009.09	1	0.10 ^g	-	0.06	0.005	-

	Euro 6	2014.09	1	0.10	-	0.06	0.005	6.0×10 ¹¹
N₁, Class II	Euro 1	1994.1	5.17	-	1.4	-	-	-
1305-1760 kg	Euro 2	1998.01	4	-	0.65	-	-	-
	Euro 3	2001.01	4.17	0.25	-	0.18	-	-
	Euro 4	2006.01	1.81	0.13	-	0.1	-	-
	Euro 5	2010.09	1.81	0.13	-	0.075	0.005	-
	Euro 6	2015.09	1.81	0.13	-	0.075	0.005	6.0×10 ¹¹
N₁, Class III	Euro 1	1994.1	6.9	-	1.7	-	-	-
>1760 kg	Euro 2	1998.01	5	-	0.8	-	-	-
	Euro 3	2001.01	5.22	0.29	-	0.21	-	-
	Euro 4	2006.01	2.27	0.16	-	0.11	-	-
	Euro 5	2010.09	2.27	0.16	-	0.082	0.005	-
	Euro 6	2015.09	2.27	0.16	-	0.082	0.005	6.0×10 ¹¹
N₂	Euro 5	2010.09	2.27	0.16	-	0.082	0.005	-
	Euro 6	2015.09	2.27	0.16 ⁱ	-	0.082	0.005	6.0×10 ¹¹

Table D.2.2 -- Emission standards for light commercial vehicles

Category	Stage	Date	CO	HC	HC+NOx	NOx	PM	PN
			g/km					
Compression Ignition (Diesel)								
N₁, Class I	Euro 1	1994.1	2.72	-	0.97	-	0.14	-
≤1305 kg	Euro 2 IDI	1998.01	1	-	0.7	-	0.08	-
	Euro 2 DI	1998.01	1	-	0.9	-	0.1	-
	Euro 3	2000.01	0.64	-	0.56	0.5	0.05	-
	Euro 4	2005.01	0.5	-	0.3	0.25	0.025	-
	Euro 5a	2009.09	0.5	-	0.23	0.18	0.005	-
	Euro 5b	2011.09	0.5	-	0.23	0.18	0.005	6.0×10 ¹¹
	Euro 6	2014.09	0.5	-	0.17	0.08	0.005	6.0×10 ¹¹
N₁, Class II	Euro 1	1994.1	5.17	-	1.4	-	0.19	-
1305-1760 kg	Euro 2 IDI	1998.01	1.25	-	1	-	0.12	-
	Euro 2 DI	1998.01	1.25	-	1.3	-	0.14	-
	Euro 3	2001.01	0.8	-	0.72	0.65	0.07	-
	Euro 4	2006.01	0.63	-	0.39	0.33	0.04	-
	Euro 5a	2010.09	0.63	-	0.295	0.235	0.005	-
	Euro 5b	2011.09	0.63	-	0.295	0.235	0.005	6.0×10 ¹¹
	Euro 6	2015.09	0.63	-	0.195	0.105	0.005	6.0×10 ¹¹
N₁, Class III	Euro 1	1994.1	6.9	-	1.7	-	0.25	-
>1760 kg	Euro 2 IDI	1998.01	1.5	-	1.2	-	0.17	-
	Euro 2 DI	1998.01	1.5	-	1.6	-	0.2	-

	Euro 3	2001.01	0.95	-	0.86	0.78	0.1	-
	Euro 4	2006.01	0.74	-	0.46	0.39	0.06	-
	Euro 5a	2010.09	0.74	-	0.35	0.28	0.005	-
	Euro 5b	2011.09	0.74	-	0.35	0.28	0.005	6.0×10^{11}
	Euro 6	2015.09	0.74	-	0.215	0.125	0.005	6.0×10^{11}
N ₂	Euro 5a	2010.09	0.74	-	0.35	0.28	0.005	-
	Euro 5b	2011.09	0.74	-	0.35	0.28	0.005	6.0×10^{11}
	Euro 6	2015.09	0.74	-	0.215	0.125	0.005 ^f	6.0×10^{11}

Table D.2.3 -- Euro norm emissions for category N3, EDC, (2000 and up)

Standard	Date	CO (g/kWh)	NO _x (g/kWh)	HC (g/kWh)	PM (g/kWh)
Euro 0	1988–92	12.3	15.8	2.6	NA
Euro I	1992–95	4.9	9.0	1.23	0.40
Euro II	1995–99	4.0	7.0	1.1	0.15
Euro III	1999–2005	2.1	5.0	0.66	0.1
Euro IV	2005–08	1.5	3.5	0.46	0.02
Euro V	2008–12	1.5	2.0	0.46	0.02

Table D.2.4 ---Euro norm emissions for (older) ECE R49 cycle

Standard	Date	CO (g/kWh)	NO _x (g/kWh)	HC (g/kWh)	PM (g/kWh)
Euro 0	1988–92	11.2	14.4	2.4	NA
Euro I	1992–95	4.5	8.0	1.1	0.36
Euro II	1995–99	4.0	7.0	1.1	0.15

D.3 Heavy-duty truck and bus engines emission standards

Table D.3.1 --- Emission standards for heavy-duty diesel engines: Steady-state testing

Stage	Date	Test	CO	HC	NOx	PM	PN	Smoke
			g/kWh					1/kWh
Euro I	1992, ≤ 85 kW	ECE R-49	4.5	1.1	8.0	0.612		
	1992, > 85 kW		4.5	1.1	8.0	0.36		
Euro II	1996.10		4.0	1.1	7.0	0.25		
	1998.10		4.0	1.1	7.0	0.15		
Euro III	1999.10 <i>EEV only</i>	ESC & EL R	1.5	0.25	2.0	0.02		0.15
	2000.10		2.1	0.66	5.0	0.10 ^a		0.8

DKS 1515: 2019

Euro IV	2005.10		1.5	0.46	3.5	0.02		0.5
Euro V	2008.10		1.5	0.46	2.0	0.02		0.5
Euro VI	2013.01	WHS C	1.5	0.13	0.40	0.01	8.0×10^{11}	

a - PM = 0.13 g/kWh for engines < 0.75 dm³ swept volume per cylinder and a rated power speed > 3000 min⁻¹

Table D.3.2 -- Emission standards for heavy-duty diesel and gas engines: Transient testing

Stage	Date	Test	CO	NMHC	CH ₄ ^a	NOx	PM ^b	PN ^e
			g/kWh					
Euro III	1999.10 <i>EEV only</i>	ETC	3.0	0.40	0.65	2.0	0.02	
	2000.10		5.45	0.78	1.6	5.0	0.16 ^c	
Euro IV	2005.10		4.0	0.55	1.1	3.5	0.03	
Euro V	2008.10		4.0	0.55	1.1	2.0	0.03	
Euro VI	2013.01	WHTC	4.0	0.16 ^d	0.5	0.46	0.01	6.0×10^{11}

a - for gas engines only (Euro III-V: NG only; Euro VI: NG + LPG)
b - not applicable for gas fueled engines at the Euro III-IV stages
c - PM = 0.21 g/kWh for engines < 0.75 dm³ swept volume per cylinder and a rated power speed > 3000 min⁻¹
d - THC for diesel engines
e - for diesel engines; PN limit for positive ignition engines TBD