

ICS 13.340.10
C 73

GB

NATIONAL STANDARD OF THE PEOPLE'S REPUBLIC OF CHINA
GB 12014-200x
Replaces GB 12014—1989

Anti-static protective clothing

(Draft Submitted for Approval)

Announced XX-XX-200X

Effective XX-XX-200X

General Administration of Quality Supervision, Inspection and Quarantine
of the People's Republic of China

Announced by:
Standardization Administration of China

Table of Contents

Foreword	II
1 Scope	1
2 Cited regulatory documents	1
3 Terms and definitions	1
4 Technical requirements	2
5 Methods of testing	4
6 Categories of inspection	4
7 Labelling	5
8 Packaging and storage	5
Appendix A (Regulatory Appendix) Point-to-point electrical resistance testing method	6
Appendix B (Regulatory Appendix) Electric charge measurement method	8
Appendix C (Regulatory Appendix) Cleaning method	10
Reference articles	11

Foreword

Clauses 4.1.2, 4.1.3, 4.2.5, 4.2.6, 4.2.7, 4.2.8, 6 and 7 of the present standard are mandatory clauses. The remainder are non-mandatory clauses.

The present standard changes GB 12014-1989 in primarily the following respects:

- adds definitions for electrostatic dissipative material, surface resistivity, and point-to-point resistance;
- adds outer appearance quality requirements for anti-static surface material;
- adds technical requirements and testing methods for anti-static surface material point-to-point resistance;
- adds technical requirements and testing methods for formaldehyde content, pH value, dimensional change, colour fastness to water, air permeability, and colour fastness to dry rubbing of anti-static surface material;
- adds tailoring requirements for anti-static protective clothing;
- adds anti-static protective clothing inspection categories;
- amends the technical requirements for electric charge and breaking force of anti-static protective clothing;
- amends grading of anti-static protective clothing;
- amends environmental conditions for testing of anti-static performance;
- deletes sizing specifications for anti-static protective clothing in Appendix C;
- deletes zone classification of places with gas explosion hazards in Appendix D.

Appendixes A, B and C of the present standard are regulatory appendices.

The present standard was put forward by the State Administration of Work Safety.

The present standard is under the jurisdiction of the National Technical Committee on Standardisation of Personal Protective Equipment.

The entity responsible for drafting the present standard: Beijing Labour Protection Scientific Research Institute.

Entities that participated in the drafting of the present standard: Shaanxi Yuanfeng Textile Technology Research Co., Ltd., Xi'an Jingcheng Professional Suits Co., Ltd., Soldier Systems Centre of the Quartermaster Research Institute of the General Logistics Department.

Primary authors of the present standard: Yang Wenfen, Zang Lanlan, Zhang Puxuan, Zhang Yan, Zong Shuqing, Wang Lixiang, Jiang Ronghua.

The present standard was first published in 1989; this is the first revision.

Anti-static protective clothing

1 Scope

The present standard specifies technical requirements, testing methods, inspection rules, and labelling for anti-static protective clothing.

The present standard applies to anti-static protective clothing worn in places where there is a risk of initiating electric shock, fire, or explosion.

The anti-static protective clothing as defined by the present standard does not apply to resistance against power supply voltage.

2 Cited regulatory documents

The clauses in the documents below become clauses of the present standard by virtue of being cited by the present standard. If a date is indicated for a cited document, no subsequent revision sheet (not including corrigenda) or amended version shall apply to the present standard. Nevertheless, the parties to agreements based on the present standard are encouraged to study whether the most recent versions of these documents can be used. If no date is indicated for a cited document, then the most recent version applies to the present standard.

GB/T 2912.1-1998 Textiles—Determination of formaldehyde—Part 1: Free and hydrolysed formaldehyde (water extraction method)

GB/T 3920-1997 Textiles—Tests for colour fastness—Colour fastness to rubbing

GB/T 3923.1-1997 Textiles—Tensile properties of fabrics—Part 1: Determination of breaking force and elongation at breaking force—Strip method

GB/T 4288-1992 Household electrical washers

GB/T 5453-1997 Textiles—Determination of air permeability of fabric

GB 7567-1987 Tests for colour fastness—Acrylic—Standard adjacent fabric

GB/T 7573-2002 Textiles—Determination of the pH value of aqueous extracts

GB/T 8628-2001 Textiles—Preparation, marking and measuring of fabric specimens and garments in tests for determination of dimensional change

GB/T 8629-2001 Textiles—Domestic washing and drying procedures for textile testing

GB/T 8630-2002 Textiles—Determination of dimensional change in washing and drying

GB/T 13640 Size designation of protective clothing

3 Terms and definitions

The following terms and definitions apply to the present standard.

3.1 anti-static protective clothing

Work clothes, whose surface material is an anti-static fabric, that are tailored in accordance with specified styles and structures in order to prevent the accumulation of static electricity on the garment surface.

3.2 anti-static protective fabric

Fabric that is made from yarn spun from fibres blended with conductive fibres or that is woven from embedded conductive filaments, or a treated fabric that has been treated to have anti-static properties.

3.3 conductive fibre

Fibres partially or fully made from metallic or organic conductive materials or electrostatic dissipative materials.

3.4 electrostatic dissipative material

Material with a surface resistivity greater than or equal to $1 \times 10^5 \Omega/\text{sq}$, but smaller than $1 \times 10^{11} \Omega/\text{sq}$.

3.5 surface resistivity

A physical quantity characterizing the conductive properties of a material object.

Note: Surface resistivity is the resistance measured between opposite sides of a material surface square and is not related to the thickness of the object or the size of the square.

3.6 point-to-point resistance

The ratio of the direct current voltage applied for a given time between two electrodes on a material's surface to the direct current flow between these two points.

4 Technical requirements

4.1 Surface material

4.1.1 Quality of outer appearance

The surface material shall be free of tears, spots, dirt or other defects that would affect the anti-static performance of the surface material.

4.1.2 Point-to-point resistance

When tested in accordance with the methods specified in Appendix A, the point-to-point resistance of the surface material shall comply with the specifications in Table 1.

Table 1 Point-to-point electrical resistance technical requirements

Test	Technical requirements	
	Level 1	Level 2
Point-to-point resistance/ (Ω)	$1 \times 10^5 - 1 \times 10^7$	$1 \times 10^7 - 1 \times 10^{11}$

4.1.3 Physicochemical properties

The physicochemical properties of the surface material shall comply with the requirements in Table 2.

Table 2 Technical requirements for physicochemical properties

Test	Technical requirement		Testing method
Formaldehyde content (mg/kg)	Direct contact with skin ≤ 75	No direct contact with skin ≤ 300	Article 5.1
pH	4.0 - 9.0		Article 5.2
Dimensional change/ (%)	+ 2.5 to -2.5 (warp, weft)		Article 5.3
Permeability to air/ (mm/s)	≥ 10 (coated surface material)	≥ 30	Article 5.4
Colour fastness to water/ (level)	$\geq 3-4$		Article 5.5
Colour fastness to dry rubbing/ (level)	$\geq 3-4$		Article 5.6
Breaking force/ (N)	warp direction ≥ 780 (mass per unit area ≥ 200 g/m ²) warp direction ≥ 490 (mass per unit area ≥ 200 g/m ²)	weft direction ≥ 390	Article 5.7

4.2 Garment

The surface material of the finished garment shall comply with the technical requirements of article 4.1.

4.2.1 Outer appearance quality

The surface material shall be free of tears, spots, dirt and other defects that would affect the wearability of the surface material.

4.2.2 Structure and style

4.2.2.1 Garment structure shall be safe, hygienic, favourable to normal physiological requirements of the human body, and healthy.

4.2.2.2 The garment shall be easy to don and to remove and shall be adapted to physical movements during work.

4.2.2.3 Garment style shall be simple, clean and practical. Depending on use requirements, one may use the following styles (see Fig. 1):

a) A "three-tight" (tight cuffs, tight collar, tight waist) shirt for the upper body and straight-leg pants for the lower body

b) Shirt and pants (or hood, feet) in one piece

c) Other styles determined according to actual conditions

4.2.2.4 In accordance with garment style and use requirements, consult GB/T 13640 size designation specifications. If out-of-spec, then size in accordance with sizing increments.

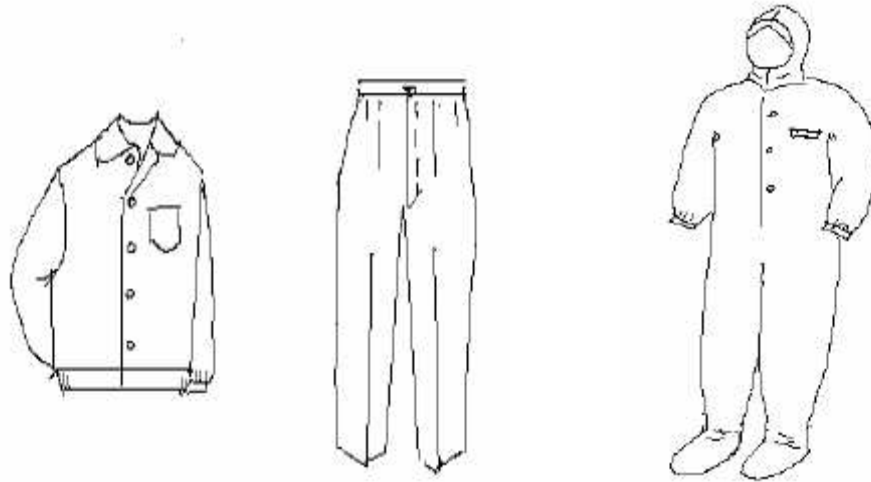

Fig. 1 Styles of anti-static protective clothing

4.2.3 Tailoring

4.2.3.1 Seams on every part of the garment shall be straight, neat, flat, and firm. They shall be appropriately tight throughout, without skipped stitches or broken threads; the first and last stitches shall be back stitches.

4.2.3.2 Stitch length of seam: 12-14 stitches/3 cm (mass per unit area ≥ 200 g/m²), 14-16 stitches/3 cm (mass per unit area < 200 g/m²).

4.2.3.3 When tested according to the methods specified in 5.8, garment seam strength shall be no less than 100 N.

4.2.4 Electric charge

When tested according to the methods specified in Appendix B, the electric charge of the anti-static protective clothing shall comply with the specifications in Table 3.

Table 3 Electric charge technical requirements

Test items	Technical requirements	
	Level 1	Level 2
Electric charge/ ($\mu\text{C}/\text{piece}$)	≤ 0.20	≤ 0.60

4.2.5 Attachments

In general, the garment shall not make use of metal attachments. If one must be used (e.g., button, hook-and-eye, zipper), its surface shall be covered; the metal attachment shall not be directly exposed.

4.2.6 Lining

Garment lining shall be anti-static fabric. The area of non-anti-static fabric pockets and reinforcement patches shall be less than 20% of the area inside the anti-static protective clothing. Winter outerwear or special garments shall be made with detachable inner liner.

4.2.7 Dimensional change

Anti-static protective clothing is cleaned and hang-dried in accordance with the 6B or 6A procedure specified in GB/T 8629-2001. Dimensional changes after washing shall comply with the specifications in Table 4.

Table 4 Dimensional change technical requirements

Test item	Dimensional change %
Collar size	≥ -1.5
Chest circumference	≥ -2.5
Shirt length	≥ -3.5

Waist	≥ -2.0
Pants length	≥ -3.5

5 Methods of testing

5.1 Select samples from different places on the surface material and the garment lining. Measure formaldehyde content in accordance with the methods specified in GB/T 2912.1-1998.

5.2 Select samples from different places on the surface material and the garment lining. Measure pH value in accordance with the methods specified in GB/T 7573-2002.

5.3 Carry out dimensional changes in accordance with the provisions in GB/T 8628-2001 and GB/T 8630-2002. Clean and hang dry using procedure 6B or 6A in GB/T 8629-2001.

5.4 Select 10 samples from different places on the surface material and the garment lining. Measure permeability to air in accordance with the methods specified in GB/T 5453-1997.

5.5 Measure the surface material's colour fastness to water in accordance with the methods specified in GB/T 5713-1997.

5.6 Measure the surface material's colour fastness to dry rubbing in accordance with the methods specified in GB/T 3920-1997.

5.7 Measure the breaking force of the surface material in accordance with the methods specified in GB 3923.1-1997.

5.8 Measure the strength of finished garment seams in accordance with the methods specified in GB 3923.1-1997. Cut out five samples having seams at their centre from places on the suit that have weak seams. The force-bearing direction is at a 90 ° angle to the seam direction. If the seam consists of a single thread, then tie knots in it at the seam ends to prevent slippage. Choose the lowest of the test results.

6 Rules of inspection

6.1 Pre-shipment factory inspection

The production enterprise shall conduct pre-shipment factory inspections of each lot of anti-static protective clothing in the order the lots are produced. See table 5 regarding test items, test sample sizes, failure classifications, and scoring sets.

Table 5 Pre-shipment factory inspection

Test	Lot quantity	Size of individual test samples	Failure classification	Individual scoring sets	
				Pass score	Fail score
Attachment	≤ 100	2	A	0	1
Lining					
Point-to-point resistance					
Electric charge	101-1,000	3	B	1	2
Dimensional change					
Breaking force					
Labelling	≥ 1,001	5	B	1	2
Quality of outer appearance	≤ 100	2			
Style	101-1,000	3			
Structure	≥ 1,001	5	B	1	2
Tailoring					

6.2 Comprehensive inspection

A comprehensive inspection must be performed in the event of any of the following:

6.2.1 new product testing or approved product trial production testing of an old product transferred to a new factory production line;

6.2.2 when the surface material, production process, or structural design changes;

6.2.3 when production resumes after a production hiatus of more than one year;

6.2.4 periodic inspection, once per year;

6.2.5 when there is a relatively large discrepancy between the results of a pre-shipment factory inspection and the results of a previous comprehensive inspection;

6.2.6 when a competent department concerned of the state requests a comprehensive inspection;

6.2.7 samples are selected randomly by the unit that initiated the inspection or by an authorized third party from among products that passed the pre-shipment factory inspection; sample quantity should be sufficient for all tests.

7 Labelling

7.1 Permanent labels

7.1.1 Each garment shall bear: product name, trademark (if any), size, name of manufacturer, and grade.

7.1.2 Each product shall have attached to it an approval certificate containing the following information: name of manufacturer, manufacturer address, contact telephone number, production date, and standard number.

7.1.3 Each product shall have attached to it product instructions for use and the mark or tag required by the relevant state or industry standard.

7.2 Product instructions

Product instructions shall include:

—Do not don or remove anti-static protective clothing in places with fire or explosion hazards.

—Do not attach or wear any metal object on anti-static protective clothing worn in places with fire or explosion hazards.

—The outer garment shall entirely cover inner garments. Independently worn upper garments shall be sufficient to cover the waistline, which should not be exposed when the wearer bends at the waist.

—Anti-static protective clothing worn in places with fire or explosion hazards shall be worn with the anti-static protective shoes specified in GB 4385-1995.

—Other necessary instructions.

8 Packaging and storage

8.1 Product packaging shall, as required by customers, be neat, firm, and undamaged and contain the correct quantity of products. Inner and outer packaging shall include moisture-proof layers. The box shall contain the manufacturer's package inspection slip. The package inspection slip shall include product name, size, lot number, quantity, inspector, and inspection date. On the outer carton shall be indicated the product name, quantity, date of manufacture, name of manufacturer, and manufacturer address.

8.2 Products may not be placed together with corrosive materials. The storage place shall be dry and ventilated, with the boxes at least 20 mm from wall and ground surfaces and protected from rodents, moths, and mildew.

Appendix A
(Regulatory Appendix)
Point-to-point electrical resistance testing method

A.1 Principle

Place the test sample on a flat, insulated board, and place electrode devices on top of it. Apply a direct-current voltage between the electrode devices to measure the sample's point-to-point resistance.

A.2 Equipment**A.2.1 Test electrodes**

The test electrodes are two, 65 ± 5 mm-diameter metal cylinders. The electrode material is stainless steel or copper. The material of the electrode contact terminals is conductive plastic, with hardness 60 ± 10 (Shore A), thickness 6 ± 1 mm, and volume resistance less than 500Ω ; electrode unit weight: 2.5 ± 0.25 kg.

A.2.2 High resistance meter

High resistance meter measurement range: $10^5 \Omega$ - $10^{13} \Omega$;
Measurement precision: $\pm 5\%$ when $\leq 10^{12} \Omega$; $\pm 20\%$ when $> 10^{12} \Omega$.

A.2.3 Insulated tabletop

Surface resistance and volume resistance of the tabletop are both greater than $1 \times 10^{14} \Omega$. Its perimeter is 10 cm greater than that of the tested material. The distance between the electrodes is 300 mm.

A.3 Washing and moisture adjustment

The test samples must undergo a washing treatment and moisture adjustment prior to testing.

A.3.1 Washing treatment

Wash in accordance with the washing methods specified in Appendix C.

A.3.2 Moisture adjustment

After drying washed samples at 60 ± 10 °C for 1 h, place them under test environment conditions for 6 h.

A.4 Test samples

Select five sets of test points at different locations on the anti-static protective surface material.

A.5 Test conditions

Test environmental conditions are temperature 20 ± 5 °C and relative humidity $35 \pm 5\%$.

Note: If test is performed in other than the prescribed test environment, note the test conditions in the report.

A.6 Test procedure**A.6.1 Cleaning**

Using a paper towel moistened with a cleanser (such as propylene glycol or ethanol), wipe the lower surface of the electrodes and the upper surface of the insulated tabletop clean, and air dry.

Note: Propylene glycol and ethanol are flammable and toxic. Avoid contact with the skin, eyes, or clothing, and do not breathe in their vapours.

A.6.2 Test

Place test sample front-side up on the insulated tabletop, or place it as it would be in actual use. Place test electrode set on sample.

Test voltage 100 ± 5 V, test time 15 ± 1 s. If surface resistance is less than $10^5 \Omega$, one may lower the voltage and make a note of it in the report. Repeat the above testing process on the same sample, and select four new test points.

A.7 Test results

Take the geometric average of five measurements as the final result.

Appendix B
(Regulatory Appendix)
Electric charge measurement method

B.1 Principle

Place sample that has passed through a drum-type friction machine into a Faraday cup to measure the electric charge of the sample.

B.2 Sample

One piece of anti-static protective clothing (both upper and lower garment acceptable).

B.3 Device**B.3.1 Friction device**

Rotating drum friction machine. Its technical requirements shall comply with the specifications of Table B1.

Table B1

Item	Specification	Item	Specification
Inner diameter of drum	65 ±5 cm	Material of drum lining	Polyacrylonitrile standard cloth
Drum depth	45 ±5 cm	Number of drum paddles	More than 2
Drum rotation rate	More than 46 r/min	Air flow	More than 2 m ³ /min
Drum opening diameter	More than 30 cm		

Polyacrylonitrile standard cloth shall comply with GB 7567-1987. Replace if there is a change, such as pilling, in the outer appearance.

B.3.2 Electric charge test device

This is composed of a Faraday cup and a static electricity tester. The connections are shown in Fig. B1.

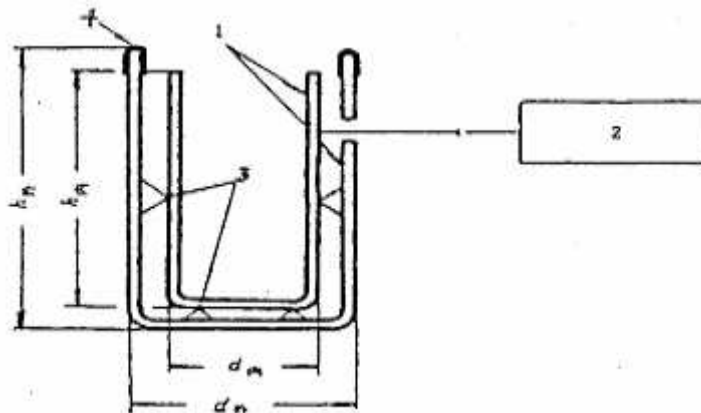
**Figure B1 Electric charge test circuit**

1—Faraday cup; 2—Static electricity tester; 3—Insulating supports; 4—Polyethylene tape

1) Faraday cup: Inner and outer metal cups, h_{inner} equals $2d_{inner}$, h_{outer} equals $2d_{outer}$, d_{inner} greater than or equal to 40 cm, d_{outer} greater than or equal to $d_{inner} + 10$ cm.

2) Static electricity tester: test range: 2nC - 2 μ C, precision: $\pm 1\%$.

3) Insulating supports: Polytetrafluoroethylene with insulation resistance above $10^{12} \Omega$.

4) Polyethylene tape: Insulation resistance above $10^{12} \Omega$.

B.4 Washing and moisture adjustment

The test samples must undergo washing treatment and moisture adjustment prior to testing.

B.4.1 Washing treatment

Wash in accordance with the washing methods specified in Appendix C.

B.4.2 Moisture adjustment

After drying washed samples at 60 ± 10 °C for 1 h, place them under test environment conditions for 6 h.

B.5 Test conditions

Test environmental conditions are temperature 20 ± 5 °C and relative humidity $35 \pm 5\%$.

Note: If test is performed in other than the prescribed test environment, note the test conditions in the report.

B.6 Test procedure

B.6.1 Place sample in drum-type friction machine, and rotate for 15 min.

B.6.2 Sample is automatically fed directly from drum-type friction machine into (or, while wearing insulated gloves with insulation resistance above 10^{12} Ω , directly remove sample and immediately drop into) the Faraday cup. At this time, be sure to keep the sample more than 300 mm from persons, metal, or other objects.

B.6.3 Static electricity tester readings shall be taken in μC .

B.6.4 In accordance with the procedure specified in Appendix B.6.1-B.6.3, repeat the test 5 times at 10 min intervals. Prior to each test, treat sample and drum lining standard cloth (should comply with GB 7576-1987) to eliminate static.

B.7 Test results

Take the average of five tests as the final measured value.

Note: If the work clothes have a lining, turn the lining inside out so that it is facing outwards. Repeat the above test steps, and record the results in the report. In the case of winter outerwear, test the front facing and the inner lining after having removed the inner liner.

Appendix C
(Regulatory Appendix)
Cleaning method

C.1 Equipment and materials

- C.1.1** Washing machine: Must comply with the whirlpool (B) washing machine specified in GB 4288-1992.
C.1.2 Ordinary thermometer.
C.1.3 Scale precise to 0.1 g.
C.1.4 pH 7-7.5 synthetic detergent.

C.2 Washing conditions

Washing conditions shall conform to the specifications in Table C1.

Table C1

Item	Condition	Item	Condition
Washing method	Ordinary wash	Concentration of liquid detergent	2 g/L
Washing temperature	(40 ±3) °C	Wash ratio	1 : 30 (fabric : water)
Water capacity	Above 30 L	Load	Add cotton white fabric

C.3 Washing procedure

C.3.1 Repeated washing

C.3.1.1 Place the samples in a washing machine that conforms to the requirements of C.1.1. After washing for 15 min in accordance with the washing conditions specified in C.2, drain and spin-dry 1 min.

8.2.1.1 C.3.1.2 Replace drained water with room-temperature clean water. After rinsing 2 min, drain, and spin-dry 1 min. Repeat 3 times until rinsed clean. Repeat steps C.3.1.1 to C.3.1.2, a total of 100 times.

C.3.1.3 Naturally air-dry samples that have been washed and spun-dry. Or, as needed, iron samples at an appropriate temperature.

C.3.2 Continuous washing

C.3.2.1 Place the samples in a washing machine that conforms to the requirements of C.1.1. Wash in accordance with the washing conditions specified in C.2.

C.3.2.2 Perform washing procedure in accordance with Table C2.

Table C2 Washing procedure

No.	1	2	3	4	5	6	7
Washing procedure	Wash 9.0 h	Drain	Spin-dry 2 min	Rinse 8.0 h	Drain	Spin-dry 2 min	Repeat 3 times in accordance with steps 4-6.

C.3.2.3 Naturally air-dry samples that have been washed and spun-dry. Or, as needed, iron samples at an appropriate temperature.

Reference Articles

- JIS T 8118---2001 Working Wears for Preventing Electrostatic Hazards
JIS L 1094---1997 Testing methods for electrostatic propensity of woven and knitted fabrics
EN 1149-1:1996 Protective clothing---Electrostatic properties Part 1 .Surface resistivity (test methods and requirements)
EN 340-2003 **Protective clothing —General requirement**
STM2.1-1997 For the Protection of Electrostatic Discharge Susceptible Items-Garments
ANSI/ESD S20.20-2007 For the Development of an Electrostatic Discharge Control Program for – Protection of Electrical and Electronic Parts, Assemblies and Equipment (Excluding Electrically Initiated Explosive Devices)
BS EN 61340-4-1:2004 Electrostatics — Part 4-1: Standard test methods for specific applications — Electrical resistance of floor coverings and installed floors
BS EN 61340-5-1-2001 Electrostatics — Part 5-1: Protection of electronic devices from electrostatic phenomena — General requirements